

# DIGITAL MICROWAVE LINKS FOR TV BROADCASTING: COMPARISON OF AVAILABLE TECHNOLOGIES

To transfer digital broadcasting TV signals (studio-broadcasting transmitter links – STL – as well as fixed and mobile contribution links), two main typologies of microwave links, based on different standards and interfaces, are available on the market:

- “**Telephone**” links -- they are based on standards which have been originally and mainly developed and used in telephony (these links normally comply with the ETSI EN 301 216 standard and employ the G703 interface with HDB3 encoding).
- “**Television**” links -- they are based on standards originally developed for digital television (DVB – ETSI EN 300 421; ETSI EN 300 429, and so on), and employ the ASI interface.

## Data transfer interfaces: ASI and G703

First, it should be understood which kind of problems these interfaces apply to; that is, in which way, with which characteristics, and in which format we have to feed our digital signals in the microwave link modulator / transmitter and in which way and format the microwave link receiver / demodulator will give us back, at the output, our digital signals.

The most commonly used interface (also foreseen in DVB standards) for compressed digital TV signals is **ASI** (**A**synchronous **S**erial **I**nterface). It's commonly employed as an input and/or output interface on multiplexers, MPEG-2 encoders, DVB-T digital modulators, and so on. The ASI interface has been mainly developed to transfer MPEG data streams (transport stream) and is extremely flexible: it can transfer useful data at any speed (bit-rate) between zero and over 200Mbit/s. For further information, please read the “DIGITAL TV BROADCASTING HANDBOOK,” downloadable from the ABE Elettronica S.p.A WEB site ([www.abe.it](http://www.abe.it)) at the following URL: [http://www.abe.it/PDF\\_Tech/DTVB\\_Handbook.pdf](http://www.abe.it/PDF_Tech/DTVB_Handbook.pdf).

The **G703** interface has been designed to transfer more 64Kbit/s data streams (please remember that a 64Kbit/s channel is a standard telephone channel).

The possible data transfer bit-rates (both in the interfaces and in the “telephone” links) are specified in the standards; the main rates of our interest, are:

- **E1**, with 2.048Mbit/s bit-rate (30 telephone channels for 64Kbit/s each + 128Kbit/s which are not used for data, but for framing, synchronization and so on – net bit-rate, which can be used for data: 1.920Mbit/s).
- **E2**, with 8.448Mbit/s bit-rate (4 times E1 + *additional bit-rate*, which is not used for data, but for *framing, synchronization*, and so on – *net bit-rate*, which can be used for data: 7.680Mbit/s). The E2 interface is obsolete and it is difficult to find the relative components and equipment.
- **E3**, with 34.368Mbit/s bit-rate (4 times E2 + *additional bit-rate*, which is not used for data, but for *framing, synchronization* and so on – *net bit-rate*, which can be used for data: 30.720Mbit/s).

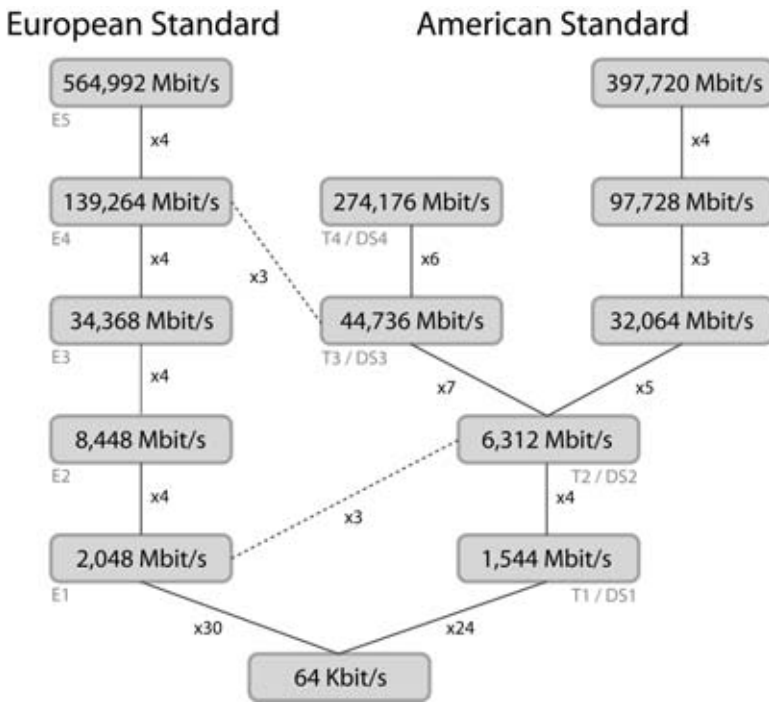
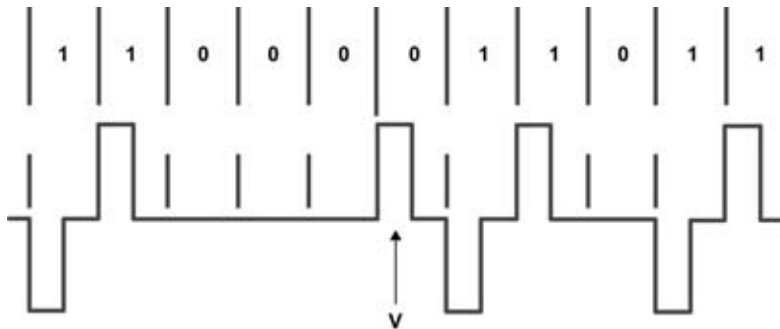

**Fig. 1** – Some standard data transfer bit-rates with the G703 interface (Plesiochronous Digital Hierarchy – PDH – that means: almost synchronous digital hierarchy).

## The HDB3 coding (for G703 interface)

The HDB3 bit coding, used for the G703 data interface, is simply a method to transmit bits, avoiding the introduction of a continuous current component, where “0”s are transmitted as “0”s and “1”s are transmitted alternatively as “+1” and “-1”, with a pulse duration equal to half bit time.

If, however, there are four consecutive “0”s, to avoid a possible synchronization loss, the sequence is transmitted by introducing a “1”, but with *polarity error*.



**Fig. 2** – HDB3 coding.

In telephone digital links, it is not possible to directly input ASI digital TV signals (Transport Stream MPEG/DVB). It is necessary to introduce an *interface converter* from ASI to G703 at the input of the link and *another interface converter* from G703 to ASI at the output.

For example, in case of a link with the E3 bit-rate interface, as previously explained, the nominal bit-rate of the link is 34.368Mbit/s, but the real usable bit-rate is 30.720Mbit/s. Therefore, despite the occupation of a 28MHz RF channel (in the most common case of a link employing QPSK modulation scheme), it will not be possible to transfer a transport stream with 31,67 Mbit/s data rate, requested if it is necessary to use the maximum capacity of an OFDM modulator/transmitter for DVB-T terrestrial broadcasting.

## The “errors” problem

Another problem to be taken into serious consideration when telephone links are used to transfer digital TV signals (transport stream MPEG/DVB) is that, normally, telephone links are developed to ensure a Bit Error Rate (BER) better than  $1 \times 10^{-6}$ .

ETSI standards for DVB digital TV broadcasting foresee a maximum of 1 erroneous bit per hour (called QEF - Quasi Error Free) which corresponds, in the worst case, to a tolerable maximum Bit Error Rate (BER) of around  $1 \times 10^{-11}$ . In order to obtain to the required Bit Error Rate (which is, indeed, necessary), *it is essential to introduce an error correction system*. Normally, the Reed-Solomon system is employed -- it adds, every 188 useful data bytes, 16 bytes for the error correction, capable to correct up to 8 non-consecutive errors in the preceding 188 bytes. To further increase the system protection level against errors, since the Reed-Solomon has difficulties with consecutive errors (when errors are in a “burst”), it is advantageous to introduce a “convolutional interleaver” which provides a “dispersion” of possible errors.

With reference to the above mentioned example of a 34Mbit/s (E3) telephone link, adding this error correction system (often necessary), the real bit rate capacity decreases from 30.720Mbit/s to 28.31Mbit/s.



**Fig. 3** – The 70MHz digital TV modulator for a microwave link, according to the DVB ETSI EN 300 421 standard, provided with multiplexers and MPEG-2 encoders (up to a maximum of 4) manufactured by ABE Elettronica S.p.A.

## Links Comparison

In conclusion, to employ **telephone links** to transfer digital TV signals, it will be necessary to use:

- Input and output interface converters
- Error correction systems at the input and at the output of the links, to ensure the requested Bit Error Rate specification for digital TV signals
- A wider frequency bandwidth than the one required, in the same conditions, employing television links
- A suitable canalization compatible with the link standard capacities.

Using **television links** for digital TV, since they are based on specifications developed to transfer and to broadcast MPEG compressed digital television signals, these problems don't exist:

- The input and output interfaces are ASI, without the need of converters
- Error correction systems enabling a  $1 \times 10^{-11}$  BER are already implemented
- the RF spectrum use is more efficient, under the same conditions as telephone links, since there is no loss of capacity for framing, synchronization, and so on
- The canalization is extremely flexible, since it is possible to occupy only the necessary RF bandwidth, according to the exact capacity (bit-rate) requested. So it is possible to adapt the link to existing canalizations (for example the system for analog links) employing at the maximum the available bandwidth.

It is wise to choose a telephone link in case of a mixed application (telephony + TV), but with widely prevalent telephone use.

## The Standards

*A final consideration concerning the standards:*

The “telephone” link standard ETSI EN 301 216 (which is, besides, not harmonized, and therefore cannot be used to directly introduce -- in the European Community market -- products manufactured according to it) specifies a series of parameters, such as link frequency stability, RF output spectrum mask and so on, but it doesn’t specify the exact modulation characteristics; therefore, as the standard itself states, it is not guaranteed any compatibility between different producers of the same equipment (a modulator produced by “A” company may not work with a demodulator produced by “B” company).

This is not the case when “television” links with modulation standards according to ETSI specifications for digital television (DVB) are used.



**ABE ELETTRONICA S.p.A.**  
Via Leonardo da Vinci, 92  
24043 • CARAVAGGIO (BG) • Italy

Tel. +39-0363-351.007 • FAX +39-0363-50.756  
[www.abe.it](http://www.abe.it)